

**CHARACTERISTICS, INSTALLATION AND MAINTENANCE
INSTRUCTIONS WITH PARTS LIST FOR**

**CRAFTSMAN $\frac{1}{2}$ H. P.
Capacitor-Start Electric Motor**

115 Volts, 60 Cycles, 1750 R.P.M.

MODEL NUMBER 115.6962

This is the model number of your Craftsman motor. It will be found on the nameplate attached to the motor. Always mention this model number when communicating with us regarding your motor or when ordering parts.

How To Order Repair Parts

All parts listed herein may be ordered through any Sears retail or mail order store. In ordering parts by mail from the mail order store which serves the territory in which you live, Selling Prices will be furnished on request or parts will be shipped at prevailing prices and you will be billed accordingly.

WHEN ORDERING REPAIR PARTS, ALWAYS GIVE THE FOLLOWING INFORMATION:

1. The Part Number in this List.
2. The Part Name in this List.
3. The Model Number of the motor.

This information is valuable. It will assure your being able to obtain proper parts service. We suggest keeping it with your valuable papers.

SEARS, ROEBUCK AND CO.

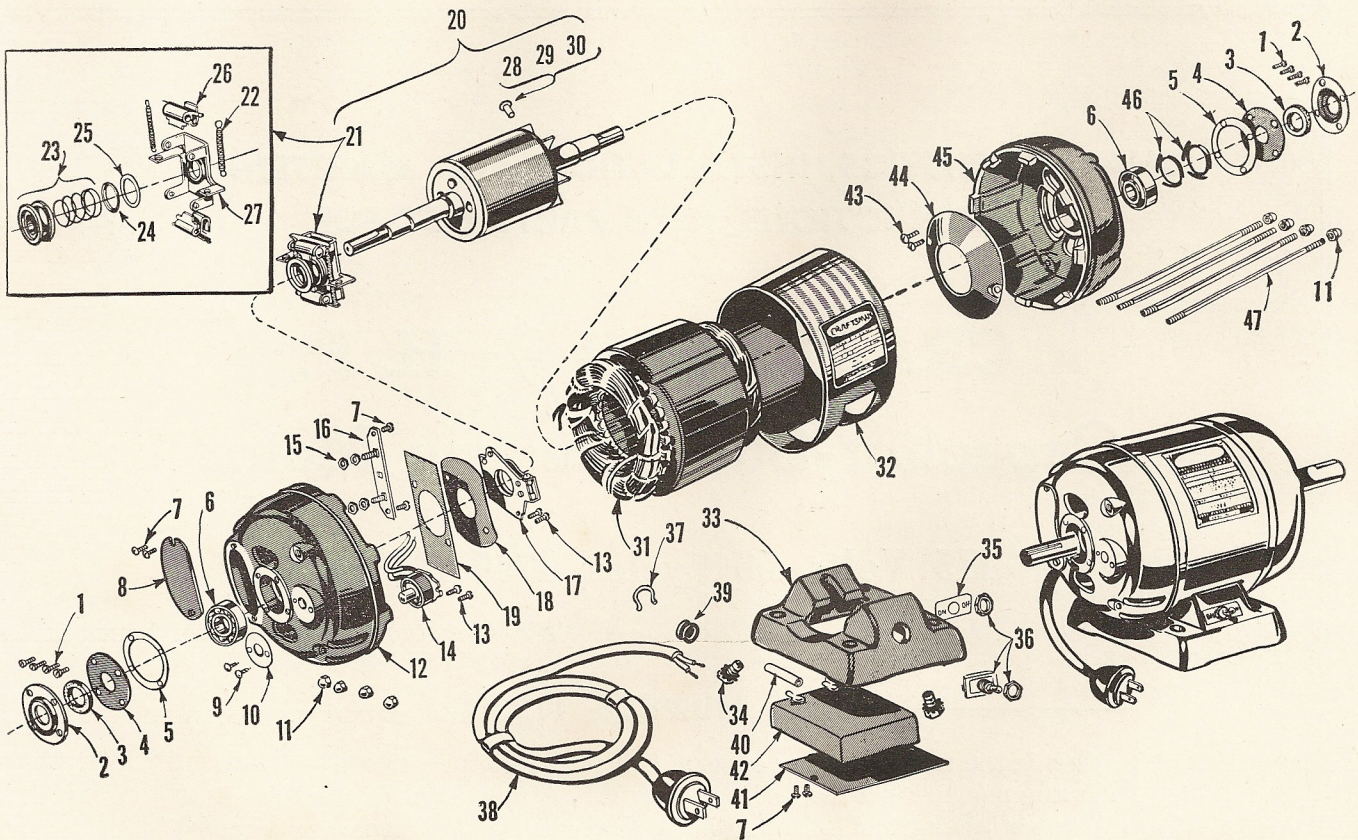

PARTS LIST Model 115.6962

Item	Part No.	DESCRIPTION	Item	Part No.	DESCRIPTION
* 1	131960	#8-32x $\frac{1}{8}$ Fillister Head Machine Screw	23	5215958	Governor Sliding Sleeve Assembly
2	5213396	Felt Retainer	24	5215895	Governor Spring Cup
3	5205305	Bearing Felt	25	5213090	Governor Washer
4	5208274	End Cap	26	5213107	Governor Finger
5	5000412	End Cap Gasket	27	5215470	Governor Back
6	908502	Ball Bearing—New Departure	28	5205726	Rotor Balancing Rivet—Heavy
* 7	5216591	#8-32x $\frac{1}{8}$ Round Head Machine Screw	29	5205727	Rotor Balancing Rivet—Medium
8	5213787	Terminal Box Cover	30	5205728	Rotor Balancing Rivet—Light
* 9	5202727	Reset Plate Drive Screw #4x3/16 Round Head	31	5216287	Stator and Coil Assembly
10	5213692	Reset Plate	32	5216291	Stator Cover Band Assembly
11	5201073	Through Bolt Nut	33	5213755	Base
12	5213623	End Frame (Switch End)	34	423351	Base Bolt Assembly
*13	115607	#8-32x $\frac{1}{8}$ Round Head Machine Screw	35	5213741	Toggle Switch Plate
14	5216339	Overload Protector Assembly	36	5214281	Toggle Switch Assembly
*15	113103	#8-32 Hex Terminal Post Nut	37	044617	Cord Strain Relief
16	5217906	Terminal Bar Assembly	38	5217010	Cord Assembly
17	5215107	Switch Assembly	39	5000254	Rubber Grommet
18	5209061	Switch Insulation	40	5201637	Sleeve Insulator
19	5213750	Switch Shield	41	5205003	Condenser Shield
20	5215723	Rotor Assembly	42	5217353	Condenser
21	5213085	Governor Assembly	*43	171350	#8-32x $\frac{1}{4}$ Round Head Air Cone Screw
22	5200990	Governor Side Spring	44	5213749	Air Cone
			45	5213747	End Frame ((Opposite Switch End)
			46	5201078	Bearing Spring
			47	5215349	Through Bolt

* Standard Hardware Items—May Be Purchased Locally.

CHARACTERISTICS, INSTALLATION AND MAINTENANCE INSTRUCTIONS

CHARACTERISTICS

The NAMEPLATE of your motor carries basic information regarding the characteristics that must be taken into consideration if you are to experience the dependable performance and long life that was designed and built into your motor.

POWER RATING

Be certain you are using a motor of the rated horsepower, speed and type recommended by the manufacturer of the unit to be driven.

TYPE

This 1/2 H.P. Craftsman motor is of the capacitor-start type and is designed to develop a high starting torque. It is particularly suitable for applications such as power tools, compressors, centrifugal and reciprocating pumps, air conditioning units, etc.

POWER SUPPLY REQUIRED

This motor is designed to operate on a power supply with the following characteristics:

1. Volts—115 (at the motor terminals).
2. Cycles or Frequency—60 (which is generally standard in the United States).

If you are not certain of your supply, inquire of your power company.

BEARINGS

Sealed ball bearings make it possible to mount this motor in any position for normal thrust load applications.

SPEED

1750 Revolutions per minute. It cannot be regulated.

ROTATION

This Craftsman motor is designed to drive in either direction. Instructions for changing the direction of rotation are provided on the motor nameplate.

OVERLOAD PROTECTION

A manual reset overload protector is located in the terminal box (switch end) of the motor. It breaks the power supply automatically before the motor overheats sufficiently to damage the windings. The motor must be allowed to cool before the overload protector can be reset. To reset, press the red button firmly with the thumb until the protector snaps into running position. Do not tap or strike the reset button.

INSTALLATION

PRE-MOUNTING CHECK

This motor was tested and inspected for electrical and mechanical performance before being packed at the factory, but as a precautionary measure the following steps should be taken before running to make certain it has not been damaged in transit.

1. Rotate the shaft with your fingers. It should turn reasonably free and smoothly.
2. Plug the motor cord into a 115 volt, 60 cycle electrical outlet and move the switch in the "on" position. Operating normally, this motor will have a low electrical hum.

MOUNTING

Mount the motor on the unit for which it was purchased, making certain all pulleys are tightened securely on their shafts and properly aligned. Proper pulley alignment can be obtained by holding a straight edge across the flat sides of the pulleys and adjusting to it. The belt tension should be such that the pressure of the fingers on the belt will deflect it readily as shown.

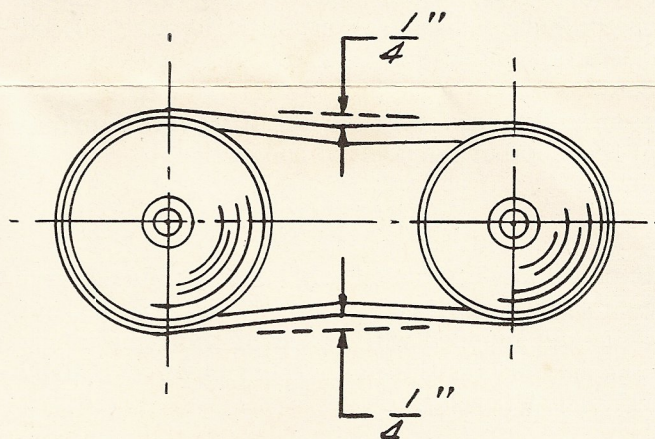

Excessive belt tension increases the motor load and bearing wear. Loose belts reduce tool efficiency and belt life. Before tightening the mounting bolts, be certain all points of the motor base are in contact with the mounting bracket on the tool or bench. Otherwise, the base may be warped or cracked. Then tighten the motor mounting bolts securely. This motor should be installed in as cool and dry a place as possible, where it will be protected from excessive deposits of dust and dirt. It should not be confined to the extent that the free flow of air through and about it is restricted.

CIRCUIT

If this motor is not required to start under load and is not overloaded after starting, the standard 15 ampere lighting circuit fuses should be satis-

factory. Otherwise, a delayed-action type fuse such as a "fustat" or "fusetron", which is designed to meet the demands of motor protection in addition to the demands of lighting circuit protection, should be used.

WIRE SIZE

The following wire sizes are recommended for extensions or special circuits from the source of power supply:

Length of Two-Conductor Extension	Wire Size Required (American Wire Gauge No.)
15 feet or less	No. 14
50 feet or less	No. 12
100 feet or less	No. 10

GROUNDING

As a precaution against the possibility of electrical shock from a ground in the motor or a static electrical charge built up in the driven unit, which is common with belt driven equipment, both units should be grounded. If the two units have metal to metal contact, grounding of either one will be sufficient protection for both. This can be accomplished by running a wire from the frame to a water pipe, steam pipe, or any other metal object making direct contact with the earth. Good electrical contact can be established between the metal surfaces and ground lead by removing all paint and other foreign material from the surface of the metal at the point of connection.

MAINTENANCE

Installed as instructed, this motor should give trouble-free service when properly lubricated, kept clean and supplied with power of the same rating as described on the motor nameplate. (Usually 115 volt, 60 cycle).

LUBRICATION

Ball Bearings used in this motor were lubricated for life at the factory.

CLEANING

Make every effort to prevent foreign materials from entering the motor. Beyond that, visually

inspect it periodically. Usually, normal accumulations of dry dust can be blown out successfully. Motors used on wood working tools, especially, should be vacuumed or blown out often to clear accumulations of saw dust that prevent proper motor ventilation and which may clog the centrifugal starting switch.

Should disassembly be necessary, refer to competent service personnel as recommended under SERVICE, since disassembly by others voids the guarantee of the manufacturer.

LOW VOLTAGE

Approximately 90% of all motor failures are the result of low voltage at the motor terminals or serious motor overloading. Although your motor is designed for operation on the voltage and frequency specified on the motor nameplate, normal loads can be handled safely on voltages that are not more than 10% above or below the rated voltage. However, heavy loads require the specified voltage at the motor terminals.

Some Causes of Low Voltage are:

1. Overloaded circuits
2. Under-sized wires
3. Overloading power company's facilities

Some Effects of Low Voltage are:

1. Motor doesn't develop full power
2. Motor starts slowly
3. Motor overheats
4. Fuses blown frequently

SERVICE

Only qualified persons who have the proper tools and equipment should attempt to service this motor. The Guarantee covering it is void if either end frame (Items 12 and 45) has been removed by anyone other than an Authorized Sears Service Station. External parts such as the cord (Item 38), Base (Item 33), Terminal Cover (Item 8), and Stator Cover Band (Item 32) may be removed without voiding the Guarantee. The nearest Sears retail or mail order store will have your motor serviced for you promptly at a reasonable rate.

GUARANTEE

This CRAFTSMAN motor was thoroughly inspected and tested before shipment. Should it fail due to faulty material or workmanship, we will repair it free of charge if returned to your Sears retail or mail order store within one year from date of purchase. This guarantee is void if the motor has been misused, abused, or disassembled.

SEARS, ROEBUCK AND CO.