

**OPERATING INSTRUCTIONS  
AND PARTS LIST FOR  
Craftsman Professional  
8-Inch Bench Saw**

**Model Numbers**

**113.1011  
113.22400**

One of the above Model Numbers will be found on a plate attached to your saw, at the back, near the bottom of the base. Always mention the Model Number when communicating with us regarding your saw or when ordering parts.

This list is valuable. It will assure your being able to obtain proper parts service. We suggest you keep it with other valuable papers.

**SEARS, ROEBUCK AND CO.**

MARCH, 1946

# Instructions for Assembling and Operating Your Saw

## Uncrating

Your Craftsman Saw comes complete (except motor) in one crate. When uncrating, remove lid, unfold sides, and unbolt saw from wood base. When unpacking, be sure to examine all packing material and paper, for parts, before discarding.

## Assembling

Clean all loose parts carefully. Best results will be obtained by assembling and checking in the following order:

1. Before shipment from the factory all saw adjustments are carefully checked. However, rough handling in transit may occasionally cause the table to shift out of proper alignment with the saw blade. The saw blade should be parallel to the mitre gage grooves in the table. If it is necessary to adjust the table, loosen the screws that hold the saw arbor assembly trunnions to the table top; readjust to make the saw blade parallel with the slots, then tighten the screws securely.

2. Check the Rip Fence Rack "J" on the front of Saw Table to make sure it has not been jarred out of line during shipment. If so, readjust parallel with the table top and tighten the four mounting screws.

3. Mount the handwheels "A" and "C" on the elevating screw, front; and the tilting screw left side.

4. Assemble the Rip Fence "F" to the Guide Rack "J" by pulling out small pinion gear knob "G" on outer bracket and sliding directly over the guide bar. Check the Rip Fence to see that it is parallel with the mitre gage slots and the saw blade. Raise the saw blade to its highest position and clamp Rip Fence in place by pushing down on lever "H" when making this test. If Rip Fence is out of line, it may be adjusted by loosening the four screws under the head and tightening when the desired adjustment is accomplished.

5. The Splitter and Guard Assembly "X" should now be mounted on the cradle. Insert the rod end of the guard into the hole in the casting at the rear of the saw; then, insert the sheet metal bracket with the semi-circular notch through the slot in the table and snap between the two wedge-type washers. Any adjustment necessary to eliminate interference between the guard and the blade may be made by loosening the screws in the casting at the rear of the saw and tightening when desired adjustment is obtained, or by readjusting the wedge-type washers. The Splitter-blade must be directly in line with the saw blade.

6. Mount motor on motor-bracket located on back of saw. (See specifications for motor on this page.) Assemble motor and bracket, sliding twin shafts on bracket into mounting holes on rear of saw. Place pulley on motor shaft and line up with saw arbor pulley. In order to obtain proper belt tension, slide motor bracket either in or out until belt is tight, keeping in mind that the motor should be allowed to fall back against the belt; thus, obtaining automatic belt tightening. When adjustment is satisfactory, clamp bracket in place by

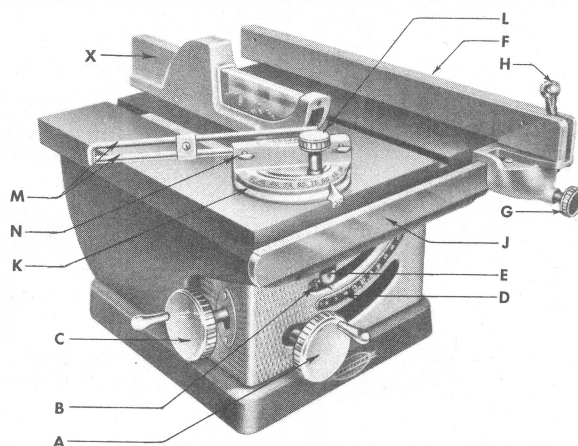

FIG. No. 1

tightening the two square head set screws. Operate saw by hand in all positions to make sure there is no interference and that belt remains tight.

If saw is to be run by a very large motor which cannot be accommodated on the motor mounting plate, the motor should be mounted on a floating rail, and a belt with a minimum length of about 80" should be used. The position of the motor should be adjusted until the belt clears all obstructions with the saw blade in any position.

If saw is to be run from lineshaft, use a belt at least 100" long.

7. Place the mitre gage assembly "K" into table slot.

8. Place the table insert in the opening to the right of the saw blade. Be sure beveled edge is next to the saw blade, with the smooth surface of the insert facing up.

## Motor Specifications

This saw is designed to be used with a 3450 rpm motor of the repulsion-induction or capacitor type; ½ hp for light duty, ¾hp for heavy duty. We strongly recommend the type shown in our catalog. The motor shaft center should be approximately four inches from the bottom of the base. If it is not, it may be necessary to obtain a different length belt. If a 1750 rpm motor is used it will be necessary to purchase a six-inch pulley and a longer belt. These may be ordered through any Sears Retail or Mail Order Store.

The arbor has been made extra long to accommodate a second pulley to provide double belt operation. The arbor pulley, motor pulley and extra belt may be ordered through any Sears Retail or Mail Order Store.

**Caution:** Under no circumstances should a six-inch motor pulley be used with a 3450 rpm motor. Also, do not use a three-inch motor pulley on a 1750 rpm motor, as the saw will not give satisfactory performance.

## Static Electricity

Sometimes a slight shock will be experienced upon touching a machine tool. This is usually caused by a static electrical charge built up by the friction between moving parts, such as between the V-belt and pulley. It is not necessarily an indica-

# Operating Instructions—Continued

tion of faulty motor windings or electrical connections. To eliminate this condition the saw should be grounded to a water or heating pipe.

## Adjustments

1. All pointers may be readily adjusted to zero position by loosening lock screw, resetting pointer, and tightening screw.
2. The Rip Fence should be set to zero with the Rip Fence just touching the teeth of the saw blade.

## Operating—Controls

The following controls should be tested until the operator is thoroughly familiar with their use.

1. Elevation Hand Wheel "A" on saw front controls elevation of blade or depth of cut as indicated on drum dial "B". To reset this dial, slide to zero position with saw blade just flush with table surface. Adjustment will be necessary when blade has been filed making it smaller than the original diameter or when using saw blades smaller than eight inches in diameter.

2. Hand Wheel "C" on left side of saw controls saw tilting. Tilting is zero degrees to forty-five degrees, and readings are taken on circular plate "D" below elevation dial.

3. Lock Lever "E" under table front, locks saw in tilted position. Tightening is obtained by operating lever in a socket-wrench manner.

4. Rip Fence "F" is operated by engaging pinion gear knob "G" with Rack "J". By turning knob "G", Rip Fence "F" will slide easily on front guide-rack. When knob "G", is pulled out of engagement with Rack "J", Rip Fence may be moved back and forth by hand. After adjusting Rip Fence to desired position, it is clamped in place by pushing down on lever "H". If clamping action is not as tight as desired, it may be adjusted by shortening the length of the tie rod, that runs through the complete length of the Rip Fence. This is accomplished by readjusting the jam nuts on the end of the rod at the back of the fence.

5. Mitre Gage "K" is graduated from ninety degrees position to thirty degrees position left and right. The clamp knob "L" locks mitre in any position. Mitre Gage is equipped with an automatic indexing lock at the 15-degree position. The extension rods "M" on mitre gage are locked in position by thumb screws "N". These rods are used when more than one piece of work, of the same length, is desired.

## Cross Cutting

Before performing cross cutting operations, be certain the alignment of mitre gage with saw blade has been checked as described under Assembly Section.

To perform accurate work, it is essential that the mitre gage be at right angles to the saw blade. This relation should be checked frequently.

**Caution:** When using the saw blade in a tilted position, the mitre gage must be used in the right hand slot because it will not clear the saw blade when used in the left hand slot.

## Ripping

Before performing any ripping operations, the rip fence gage pointer should be checked for accuracy. The width desired may be obtained very accurately and quickly by using the graduated slide bar on the front of the table as a scale. The saw blade should be high enough at all times to readily throw out the sawdust. In ripping narrow pieces, use a piece of wood to push the work through, when the end of the work is close to the saw blade, as it is dangerous to push narrow pieces with your hand.

## Disc Sanding

An 8" sanding disc (Cat. No. 9-2272, 5/8" bore) is available for converting the saw into a disc sander with full provisions for tilting to forty-five degree.

To set up the saw for disc sanding, take out the table insert plate and replace the saw blade with the sanding disc. It will be necessary to purchase a special sanding disc insert plate (Cat. No. 9-2242), for use with the disc, as the table opening is too narrow when the regular table insert plate is used. The sanding disc is furnished with a coarse and a fine abrasive. Use the coarse grit for cutting operation and the fine grit for finishing operations. The used abrasive paper can be scraped off with a sharp instrument. Use Craftsman Disc Cement (Cat. No. 9-2219) for applying new discs. Replacement discs may be ordered through any Sears Retail or Mail Order Store. (Cat. No. 9-2273, coarse, medium, or fine grit, please state which).

## Dadoing and Rabbeting

For dado work, it is necessary to use a special dado insert plate (Cat. No. 9-2210).

To use the dado head, take out the table insert plate and remove the saw blade. Place one dado blade on the arbor first, and then, the inside chipper as required to obtain the desired thickness, and finally, the outside dado blade. Replace saw collar and tighten nut securely.

When dado assemblies wider than 5/8" are to be used, it will be necessary to leave the outside washer off the arbor and tighten nut securely against outer dado blade.

**Caution:** Do not use the chipper blades by themselves, without the outside dado blade.

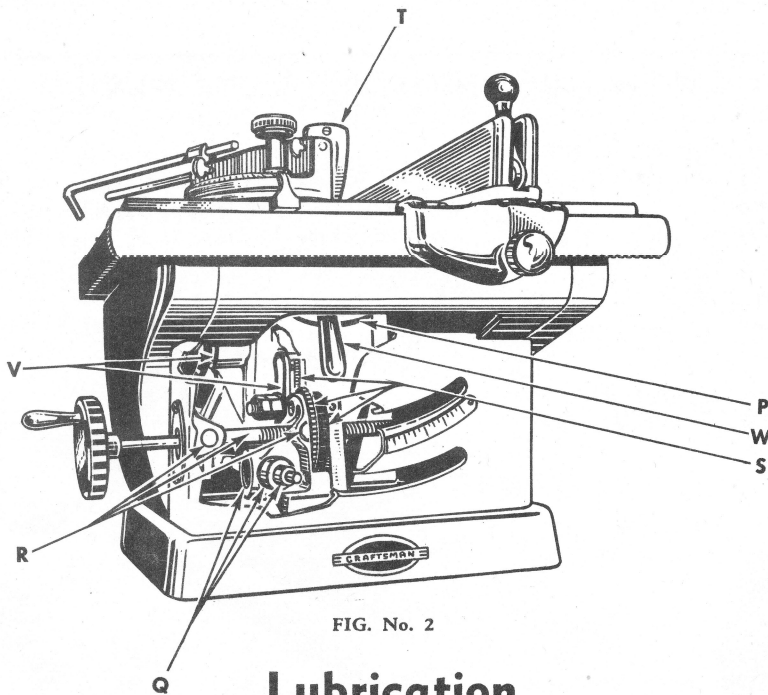

FIG. No. 2

## Lubrication

Your saw is a fine machine and should be given the best of care. Keep it clean, lubricate it regularly, and it will give you many years of trouble-free service.

For points requiring lubrication, refer to Figure No. 2 above.

### Greasing

The saw arbor ball bearings are lubricated by means of a grease cup which is accessible through the back of the saw. The bearings are lubricated at the factory and will give approximately 3,000 hours of operation before re-lubrication is necessary. To lubricate, fill cup with good grade of light ball bearing grease. By turning cup, grease is forced into bearing. Do not over-lubricate or pack these bearings.

### Oiling

The following parts should be oiled frequently with SAE 20 or 30 automobile engine oil:

1. Trunnion Segments "P" in which cradle tilts.
2. Saw height worm screw bearing and thread "Q".
3. Saw tilt screw bearings and thread "R".
4. Height gage bearing and gear "S".
5. Saw guard "T".
6. Saw arm hinge shaft and guide "V".
7. Saw tilt clamp "W".
8. Other points where there is friction between two or more moving surfaces or where a slip fit is necessary for adjusting purposes.
9. Special attention should be given to the moving parts in the Rip Fence and Mitre Gage.

To prevent saw table from rusting, keep covered with film of oil when not in use. Wipe off with cloth before using. If saw is used in damp location, follow a similar procedure for other unfinished parts of the saw as a protection against rust and corrosion.

## Instructions For Ordering Parts

All parts illustrated in Figure Nos. 3 and 4 and listed on the following pages under part numbers may be ordered through any Sears Retail or Mail Order Store. Bolts, washers, nuts, etc., are standard items and may be purchased locally by noting the specifications listed for the parts.

All parts are shipped prepaid within the limits of continental United States.

In several instances part numbers and prices are listed for COMPLETE ASSEMBLIES. However, the COMPLETE ASSEMBLY part numbers do not appear on the illustrations.

When ordering always give the following information:

1. Model number of your saw.
2. Part number shown in this list.
3. Description of Part shown in this list.
4. Price shown in this list.

All prices are subject to change without notice.

### Sample Order

Sears, Roebuck and Co.

Enclosed find my check for \$3.90 for which please send me the following parts for my Craftsman Saw Model No. 113.1011.

- |   |       |        |
|---|-------|--------|
| 1 ea. Part No. 78 Guard                 | ..... | \$3.00 |
| 1 ea. Part No. 80 Guard (8" Saw) Insert | ..... | .68    |
| 1 ea. Part No. 28 Saw Arbor Nut         | ..... | .22    |

Yours truly,

C. V. Casten  
Box 239  
Pleasantville, Ill.

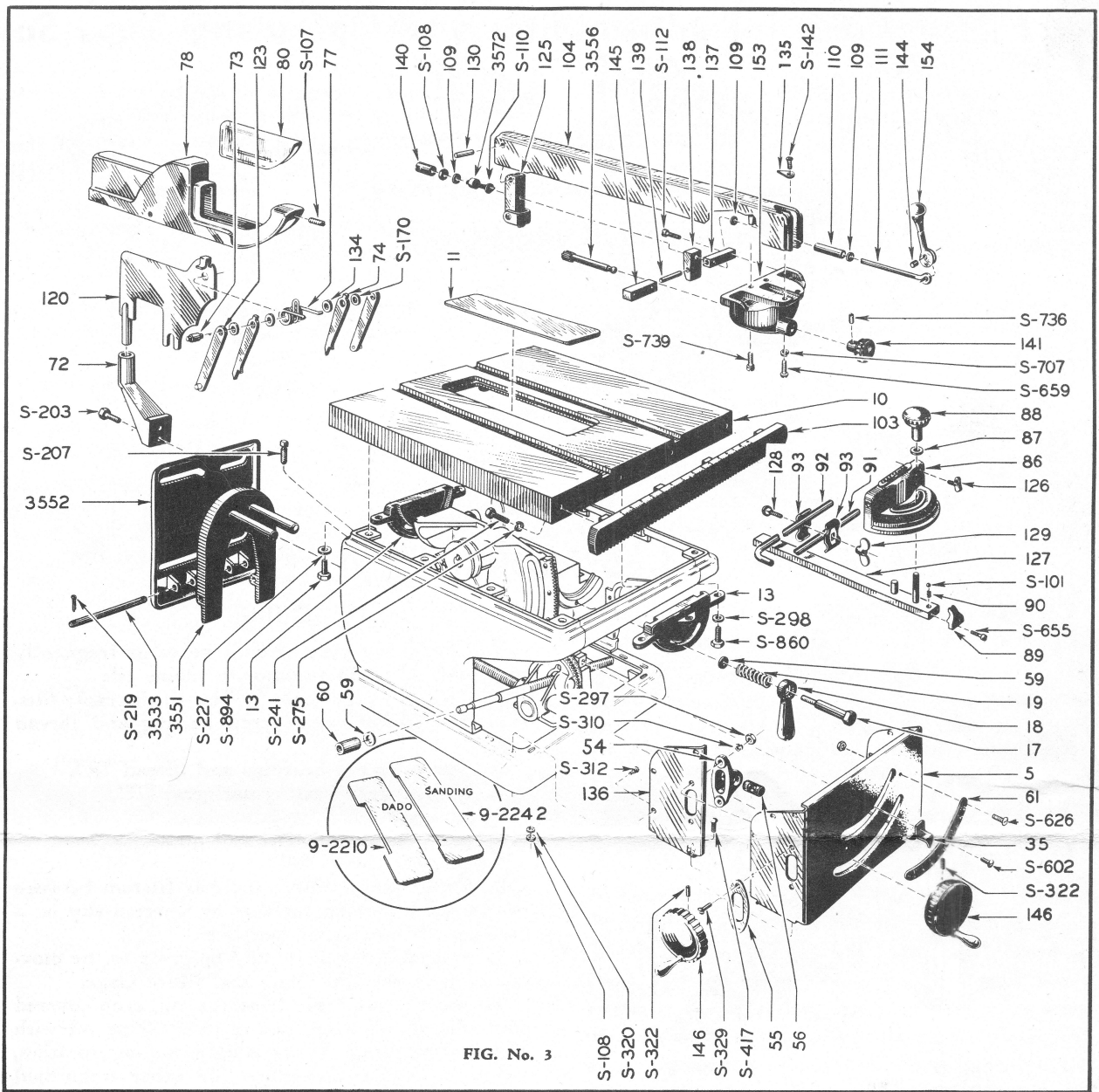

### FIGURE 3 PARTS LIST

Part No.	NAME OF PART	Prepaid Price Each
82	MITRE GAGE ASSY.....	\$ 4.20
86	Mitre Gage	1.76
87	Mitre Gage Washer	.10
88	Mitre Clamp Knob	.38
89	Mitre Gage Pointer	.20
90	Mitre Gage Spring	.10
91	Mitre Exten. Rod (Straight)	.30
92	Mitre Extension Rod	.35
93	Mitre Rod Clamp	.10
126	Mitre Thumb Screw	.11
127	Mitre Gage Clamp Assembly	1.56
128	Carriage Bolt (3/16" Dia. x 3/4")	.10
129	Wing Nut 10-24	.10
S-101	7/32 Dia. Steel Ball	.10
3553	MOTOR SUPPORT ASSEM.	5.08
3533	Motor Support Hinge Rod	.28
3551	Motor Base Support Assem.	3.04
3552	Motor Base Bracket Assy.	2.12
66	GUARD ASSEMBLY	4.98
73	Splitter Pivot Pin	.14
74	8" Saw Pawl	.12
77	Pawl Spring	.13
78	Guard	3.00

Part No.	NAME OF PART	Prepaid Price Each
80	Guard (8" Saw) Insert	.68
120	Splitter (8" Saw) Blade Assy.	1.26
123	Link Pin Assembly	.20
134	Link Spring Spacer	.11
S-170	17/32 x 3/4 x .059 Steel Washer	.10
101	RIP FENCE ASSEMBLY	9.12
104	Rip Fence	5.14
109	Rip Fence Clamp Washer	.10
110	Rip Fence Clamp Sleeve	.16
111	Rip Fence Clamp Rod	.44
125	Rip Fence Arm Assembly	.30
130	Rip Fence Clamp Pin	.11
135	Rip Fence Indicator	.10
137	Rip Fence Clamp R.H. Retainer	.22
138	Rip Fence Clamp	.25
139	Rip Fence Clamp Pin	.11
140	Rip Fence Clamp Sleeve Nut	.18
141	Rip Fence Knob	.40
144	Cam Lever Pin	.10
145	Rip Fence Clamp L.H. Retainer	.22
153	Rip Fence Guide	1.90

Part No.	NAME OF PART	Prepaid Price Each
154	Cam Clamp Lever	.48
3556	Rip Fence Pinion	.44
3572	Rip Fence Clamp Cushion	.10
5	Front Panel	2.64
10	Table	19.00
11	Insert	1.12
13	Table Trunnion	1.54
17	Clamp Screw	.22
18	Clamp Screw Handle	.34
19	Clamp Screw Spring	.10
35	Tilt Lift Pointer	.11
54	Tilt Bearing Bracket	.68
55	Tilt Bearing Plate	.14
56	Tilt Screw Block	.30
59	Fitting Screw Washer	.10
60	Tilting Screw Sleeve	.16
61	Tilt Gage	.26
72	Splitter Blade Bracket	1.48
103	Fence Slide Gear Rack	2.26
136	Front Panel Stiffener	.82
146	3 1/8" Inch Hand Wheel Assy	1.78
S-298	380 x 7/8 x 1/16 Steel Washer	.10

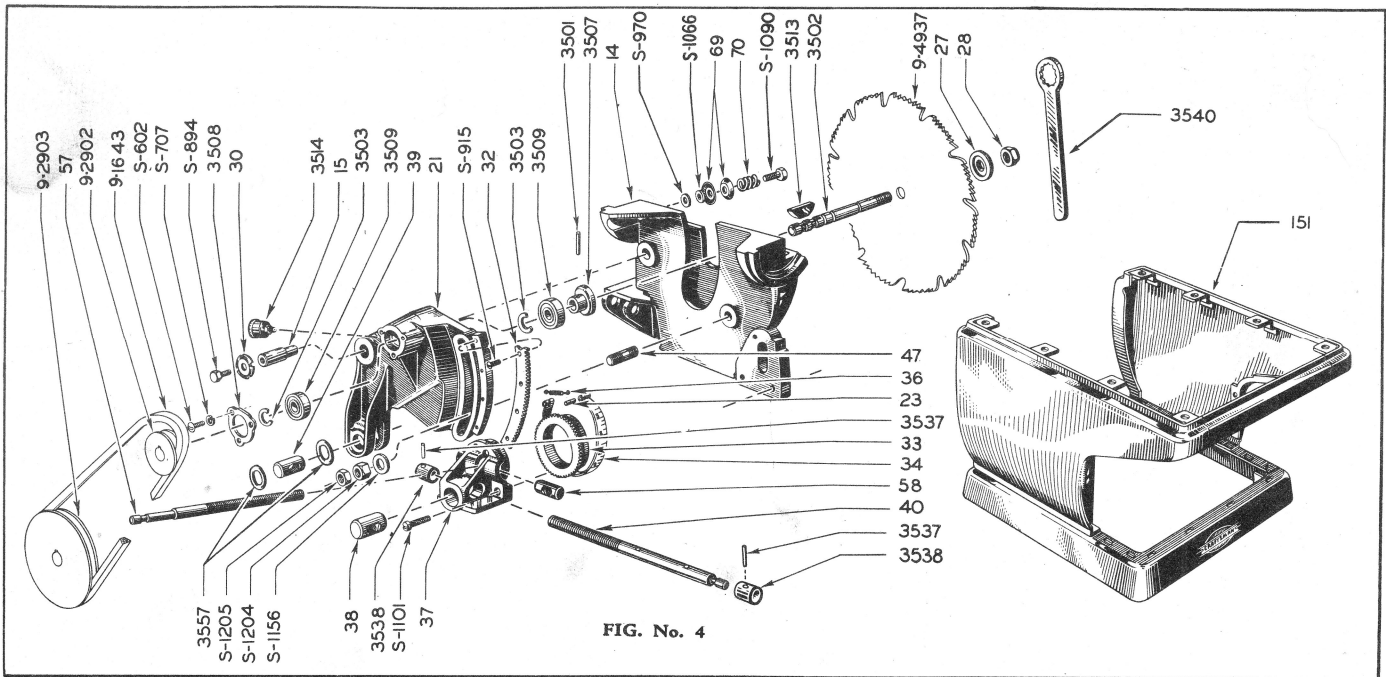

FIG. No. 4

**FIGURE 4 PARTS LIST**

Part No.	NAME OF PART	Prepaid Price Each	Part No.	NAME OF PART	Prepaid Price Each	Part No.	NAME OF PART	Prepaid Price Each
67	DEPTH DIAL ASSEMBLY	\$ 0.78	3506	SAW ARBOR ASSEMBLY	2.34	30	Spindle Arm Pin Retaining Washer	.10
23	Lift Dial Tape Pin	.10	3501	Tight Collar Pin	.10	32	Depth Dial Rack	.28
33	Dial Gear	.50	3502	Saw Arbor	.92	27	Tilt Lift Nut Bracket	1.42
34	Lift Dial Tape	.24	3503	Saw Arbor Shaft Snap Ring	.10	38	Lift Screw Block	.60
36	Lift Dial Tape Spring	.13	3507	Tight Collar	.30	39	Lift Nut	.40
3505	SAW ARBOR HOUSING ASSEMBLY	10.72	3509	Saw Arbor Bearing	.94	47	Saw Arbor Retaining Stud	.17
21	Saw Arbor Housing	6.36	3539	LIFT SCREW ASSEMBLY	1.68	57	Tilt Screw	.98
27	Loose Collar	.25	40	Lift Screw	1.34	58	Tilt Nut	.32
28	Saw Arbor Nut	.22	3537	Pin	.10	69	Splitter Blade Clamp Washer	.10
3508	Arbor Bearing Retainer	.11	3538	Lift Screw Collar	.20	70	Spring Splitter Blade Clamp	.10
3513	Saw Arbor Key	.10	14	Cradle	12.06	151	Saw Base Assembly	9.66
3514	Grease Cup	.16	15	Spindle Arm Pin	.25	3540	Arbor Wrench	.32
						3557	Lift Nut Washer	.10

**THE FOLLOWING PARTS SHOWN ON FIGURES 3 AND 4 ARE STANDARD AND CAN BE PURCHASED LOCALLY:**

Part No.	NAME OF PART	Prepaid Price Each	Part No.	NAME OF PART	Prepaid Price Each	Part No.	NAME OF PART	Prepaid Price Each
S-107	8—32 x 5/8 Cone Pt. Set Screw	\$ 0.10	S-312	10—3/8 Style Z Rd. Hd. Sheet Metal Screw	.10	S-707	3/16 SAE Med. Lockwasher	.10
S-108	10—32 x 1/8 Hex Nut	.10	S-320	13/16 x 7/16 x 1/32 Steel Washer	.10	S-736	10—32 x 3/16 Cup Pt. Set Screw	.10
S-110	SAE No. 10 Washer	.10	S-322	10—32 x 1/4 Cup Pt. Set Screw	.10	S-739	10—32 x 5/8 Fil. Hd. Machine Screw	.10
S-112	10—32 x 1/2 Fil. Hd. Machine Screw	.10	S-329	1/4—20 x 1 Rd. Hd. Machine Screw	.10	S-860	3/8—16 x 3/4 Hex. Hd. Cap Screw	.10
S-142	10—32 x 5/16 Rd. Hd. Machine Screw	.10	S-417	10—32 x 1/2 Rd. Hd. Machine Screw	.10	S-894	3/8—16 x 1/2 Hex. Hd. Cap Screw	.10
S-170	17/32 x 3/4 x 1/16 Steel Washer	.10	S-602	10—32 x 3/8 Rd. Hd. Machine Screw	.10	S-915	8/32 x 3/8 Rd. Hd. Machine Screw	.10
S-203	5/16—18 x 3/4 Hex. Hd. Cap Screw	.10	S-626	8—5/16 Style Z Sheet Metal Screw	.10	S-970	7/16 x 3/4 x .024 Steel Washer	.10
S-207	5/16—18 x 7/8 Sq. Hd. Set Screw	.10	S-655	6—32 x 3/8 Fil. Hd. Machine Screw	.10	S-1066	7/16 x 3/4 x 1/32 Steel Washer	.10
S-219	3/32 x 1/2 Cotter Pin	.10	S-659	10—32 x 7/8 Rd. Hd. Machine Screw	.10	S-1090	3/8—16 x 1/4 Hex. Hd. Cap Screw	.10
S-227	7/16 x 1 x .083 Steel Washer	.10				S-1101	5/16—18 x 1 Fil. Hd. Cap Screw	.10
S-241	5/16—18 x 7/8 Hex. Hd. Cap Screw	.10				S-1156	9/16 x 1 3/4 x 7/64 Steel Washer	.10
S-275	5/16 SAE Med. Lockwasher	.10				S-1204	1/2—13 Semi-Fin. Hex. Nut	.10
S-297	1/4—20 x 3/16 Hex. Nut	.10				S-1205	1/2—13 Semi-Fin. Hex. Jam Nut	.10
S-310	1/4 SAE Med. Lockwasher	.10						

**THE FOLLOWING PARTS SHOWN ON FIGURES 3 AND 4 MAY BE ORDERED THROUGH ANY SEARS RETAIL OR MAIL ORDER STORE:**

Stock No.	NAME OF PART
9-2210	Dado Insert
9-2242	Sanding Insert
9-2272	Sanding Disc, 3/8" bore (not illustrated)
9-2902	2 1/2" x 5/8" Bore Hubless Arbor Pulley
9-2903	3" x 3/8" Bore Hubless Motor Pulley
9-1643	43" x 1/2" V Belt
9-4937	8" x 3/8" Bore Comb. Tooth Saw Blade